



CITY OF INDIAN ROCKS BEACH
1507 BAY PALM BLVD. INDIAN ROCKS BEACH, FL. 33785
(727)595-2517
Email to Mike Kelley at mkelley@irbcity.com

PRIVATE DOCK PERMIT APPLICATION

<input type="checkbox"/> APPROVED <input type="checkbox"/> DENIED _____ City of Indian Rocks Beach Official Date _____ Permit Fee: _____ Permit required from Pinellas County <input type="checkbox"/> YES <input type="checkbox"/> NO If yes, deliver approved City of Indian Rocks Beach Dock Permit to Pinellas Water & Navigation 315 Court Street Clearwater, FL 33756. (727) 464-3385

I. PROPERTY OWNER INFORMATION:

- A. Applicant's Name: _____
- B. Mailing Address: _____
City: _____ State: _____ Zip: _____
- C. Telephone No: _____ E-mail Address: _____

II. AGENT INFORMATION:

- A. Name: _____
- B. Address: _____
City: _____ State: _____ Zip: _____
- C. Telephone No: _____ E-mail Address: _____

III. SITE INFORMATION:

- A. Construction Site Address: _____
City: _____ State: _____ Zip: _____
- B. Parcel ID Number: ____/____/____/____/____/____

IV. PROJECT DESCRIPTION:

- A. Nature and Size of Project:

_____ Square Feet: _____



V. CONTRACTOR INFORMATION:

I, _____, a certified contractor, state that the dock has not been constructed and that it will be built in compliance with all requirements and standards set forth in the City of Indian Rocks Beach Code, and in accordance with the attached drawings which accurately represent all the information required to be furnished. In the event that this dock is not built in accordance with the permit or the information furnished is not correct, I agree to either remove the dock or correct the deficiency.

Signed: _____ Cert No.: _____

Company Name: _____ Telephone No: _____

City: _____ State: _____ Zip: _____

E-mail Address: _____

VI. OWNER'S SIGNATURE:

I hereby apply for a permit to do the above work and state that the same will be done according to the map or plan attached hereto and made a part hereof, and agree to abide by the criteria of the City of Indian Rocks Beach Code for such construction. I further state that said construction will be maintained in a safe condition at all times, should this application be approved, that I am the legal owner of the upland from which I herein propose to construct the improvements, and that the above stated agent/contractor may act as my representative. I understand that I, not the City of Indian Rocks Beach, am responsible for the accuracy of the information provided as part of this application and that it is my responsibility to obtain any necessary permits and approvals applicable for the proposed activities on either private or sovereign owned submerged land.

Date

Legal Owner's Signature



DISCLOSURE FORM

In order to alleviate any potential conflict of interest with City of Indian Rocks Beach staff, it is required that the City be provided with a listing of PERSONS being party to a trust, corporation, or partnership, as well as anyone who may have beneficial interest in the application which would be affected by any decision rendered by the City (attach additional sheets if necessary).

A. PROPERTY OWNERS:

Name: _____

Name: _____

Address: _____

Address: _____

Name: _____

Name: _____

Address: _____

Address: _____

B. REPRESENTATIVES:

Name: _____

Name: _____

Address: _____

Address: _____

C. OTHER PERSONS HAVING OWNERSHIP INTEREST IN THE SUBJECT PROPERTY:

Interest is: contingent absolute

Name: _____

Specific interest held: _____

D. OWNER'S SIGNATURE:

I hereby certify that the information stated above is complete, accurate, and true to the best of my knowledge.

X _____ Date _____



PRIVATE DOCK

MHW

MLW

BOTTOM

Profile View

ENG. SCALE: 1" = 20'



TOTAL SQUARE FEET _____

NEW SQUARE FEET _____

WATER WAY WIDTH _____

WATERFRONT WIDTH _____

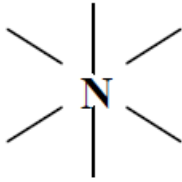

Plan View - (applicant and adjacent docks)

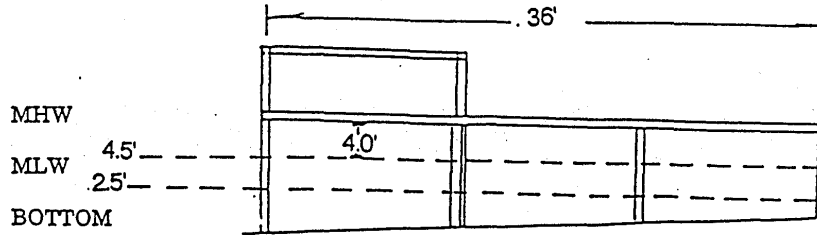

Profile View

ENG. SCALE: 1" = 20'

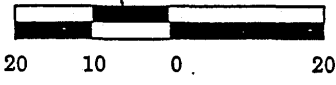

TOTAL SQUARE FEET	240
WATERWAY WIDTH	180'
WATERFRONT WIDTH	60'

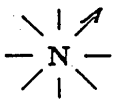

Plan View
(applicant and adjacent docks)

SAMPLE

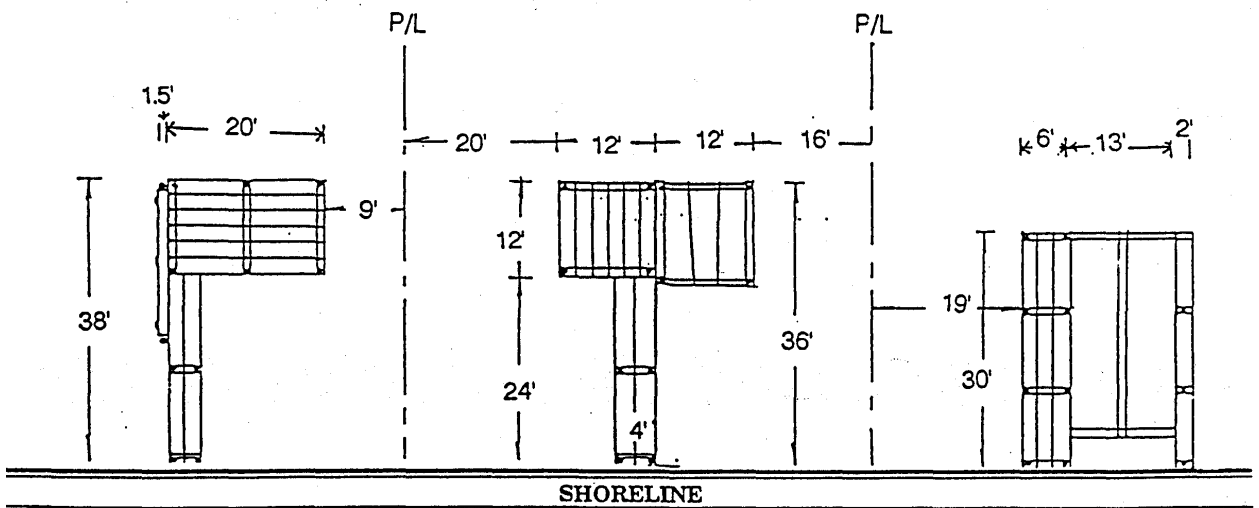



CITY OF INDIAN ROCKS BEACH, FLORIDA
DOCK WATER DEPTH AFFIDAVIT

I, the undersigned contractor, who is duly licensed to construct and repair docks in Pinellas County, Florida, do hereby attest to the following:

1. On behalf of my client, I do hereby propose to construct a dock in the City of Indian Rocks Beach that has a length of thirty five (35') feet, or longer if necessary to reach thirty six (36") inches of water depth at a mean low water mark. In no case shall the length exceed fifty (50') feet beyond the property line, seawall of mean high water mark, whichever is applicable pursuant to Section 94-87 of the City Code; and

2. I, or personnel under my supervision, have inspected the proposed construction site for the subject dock and have taken measurements at the proposed construction site in accordance with generally accepted standards and have determined that the depth of the water at the subject location at mean low tide of thirty six (36") inches at a distance of _____ from the seawall as measured perpendicular to the seawall.

Signature of Contractor/Authorized Agent

The above instrument was acknowledged before me this _____ day of _____, 20____, by _____, who is personally known to be or who produced _____ as identification.

Notary Stamp

Notary Signature

Name (print): _____

Title/Rank: _____